

CYCLONE

SPEAKER MOUNTING KIT

SPBRK-37

2015-2017 Ford F-150

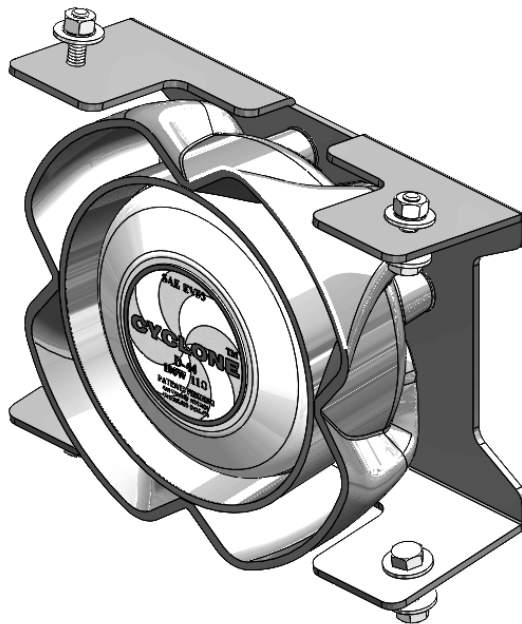

!!! WARNING !!!

Devices should be mounted only in locations listed in SAE standard J1849. Assure clearances before drilling in vehicle. Sound levels produced by speakers can cause permanent hearing loss. Never operate this unit without adequate hearing protection for you and others in the area. (OSHA 1910.95)



WARNING: ALWAYS WEAR HEARING PROTECTION PER OSHA 1910.95



Star Headlight & Lantern Co., Inc.

455 Rochester Street Avon, NY 14414 Phone: 585-226-9787 FAX: 888-478-2797

STAR
WARNING
SYSTEMS

STAR SIGNAL
VEHICLE PRODUCTS

BRADFORD
Vehicle Solutions

www.starheadlight.com

PLIT427-37 REV. - 2/13/17

Installation



WARNING: ALWAYS WEAR HEARING PROTECTION PER OSHA 1910.95

This bracket mounts in the grille where the license plate normally sits. The license plate will need to be removed and relocated.

1. Remove the license plate bracket and lower grille from the bumper following factory specifications.
2. Across each of the four tabs that the grille mounts to, draw a line even with the bottom indentation in the bumper (Fig. 1)

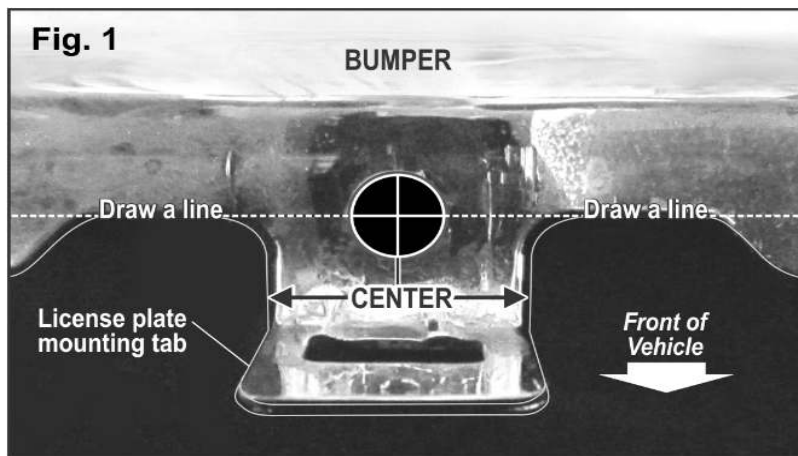

3. On the drawn line centered above each tab, mark the location of each of the four mounting holes you will be drilling on the bumper.
4. Drill a 1/4" hole through the bumper in each of the four marked locations.
5. Slide the top and bottom of the mounting bracket under the bumper, aligning it with the mounting holes (Fig. 2)

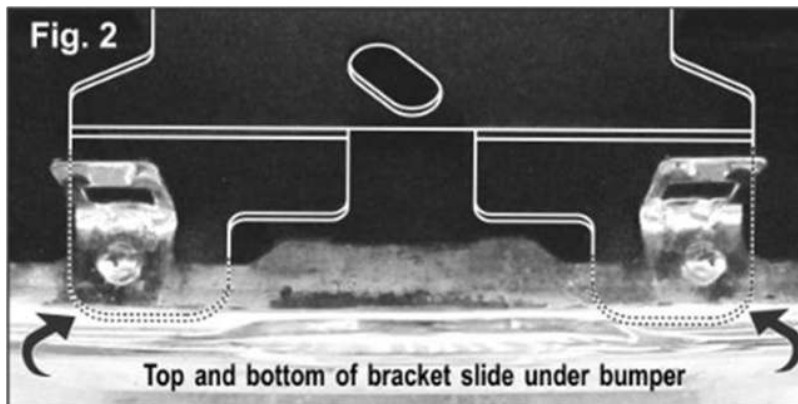

6. Secure the mounting bracket to the vehicle using the 1/4-20 nickel plated brass nuts and the 1/4-20 x 3/4" Phillips pan head machine screws. (Fig. 3).

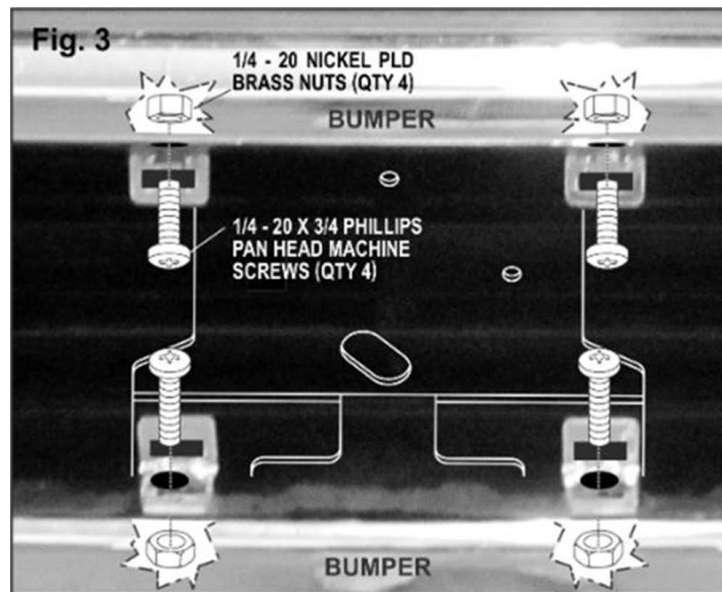

7. Mount speaker to bracket (Fig. 4)
- Remove three (4) bolts from back of D-44 speaker.
 - Speaker wires must exit bottom of speaker. (Fig. 5)
 - Apply thread locking compound to threads.
 - Align the holes in the bracket and speaker and re-install the four bolts torquing them to 30 in-lbs.

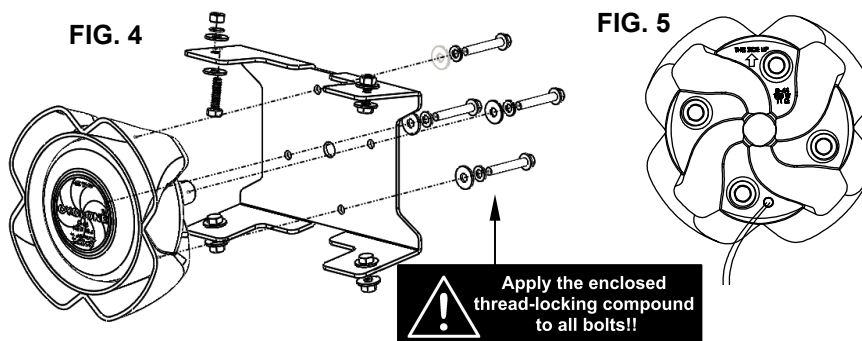

IMPORTANT!

Speaker must be mounted with drain hole/wiring exit facing down. Failure to do so will void warranty!

8. Replace the grille that was removed in Step 1. You will need to trim part of the grille so that it fits around the speaker. If needed, use the supplied double sticky tape to secure the grille after it is trimmed.
9. Route wires:
 - Route wires so they are not in contact with any sharp or abrasive surface.
 - Fasten securely to nearby features.
 - Refer to siren installation manual for wiring connections.

ONE YEAR LIMITED WARRANTY

The manufacturer warrants each new product against factory defects in material and workmanship for one year after the date of purchase. The owner will be responsible for returning to the Service Center any defective item(s) with the transportation costs prepaid. The manufacturer will, without charge, repair or replace *at its option*, products, or part(s), which its inspection determines to be defective. Repaired or replacement item(s) will be returned to the purchaser with transportation costs prepaid from the service point. A copy of the purchaser's receipt must be returned with the defective item(s) in order to qualify for the warranty coverage. Exclusions from this warranty include, but are not limited to, bulbs, strobe tubes, domes, and/or the finish. This warranty shall not apply to any light, which has been altered, such that in the manufacturer's judgment, the performance or reliability has been affected, or if any damage has resulted from abnormal use or service.

There are no warranties expressed or implied (including any warranty of merchantability or fitness), which extend this warranty period. **The loss of use of the product, loss of time, inconvenience, commercial loss or consequential damages, including costs of any labor, are not covered.** The manufacturer reserves the right to change the design of the product without assuming any obligation to modify any product previously manufactured.

This warranty gives you specific legal rights. You might also have additional rights that may vary from state to state. Some states do not allow limitations on how long an implied warranty lasts. Some states do not allow the exclusion or limitation of incidental or consequential damages. Therefore, the above limitation(s) or exclusion(s) may not apply to you.

If you have any questions concerning this or any other product, please contact our **Customer Service Department** at (585) 226-9025.

If a product must be returned for any reason, please contact our Customer Service Department to obtain a Returned Materials Authorization number (RMA #) before you ship the product back. Please write the RMA # clearly on the package near the mailing label.

Please Note: These instructions are provided as a general guideline only. **Specific mounting, wiring, and/or weather-sealing may be necessary and are the sole responsibility of the installer. The manufacturer assumes no responsibility for the integrity of the installation for this or any of its products.**



PROUDLY MADE IN THE USA
An ISO 9001:2008 Certified Company