

CYCLONE SPEAKER MOUNTING KIT

SPBRK-42 SINGLE OR DUAL D-44 BRACKET (FITS 2020-2022 FORD F-150)

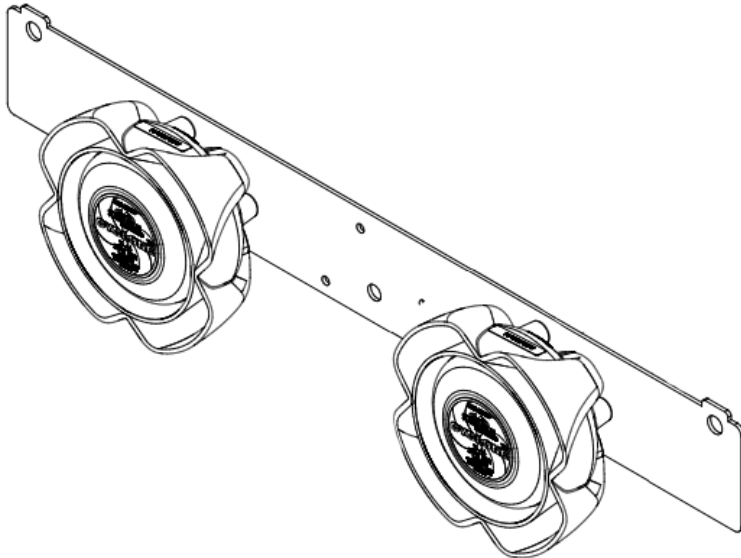

Please Note: These instructions are provided as a general guideline only. Specific mounting, wiring, and/or weather-sealing may be necessary and are the sole responsibility of the installer. The manufacturer assumes no responsibility for the integrity of the installation for this or any of its products.



WARNING: ALWAYS WEAR HEARING PROTECTION PER OSHA 1910.95

STAR
Safety Technologies by *Crote*

455 Rochester Street Avon, NY 14414
585-226-9500 (F) 888-478-2797
www.StarSafetyTechnologies.com

PLIT427-42 REV. A 2/16/24

Installation

This bracket is designed to install directly to the existing bolts and should require no drilling or additional hardware.



IMPORTANT!
Speaker must be mounted with
drain hole/wiring exit facing down.
Failure to do so will void warranty!



1. Attach the speakers to the bracket as pictured below (dual-speaker setup shown).

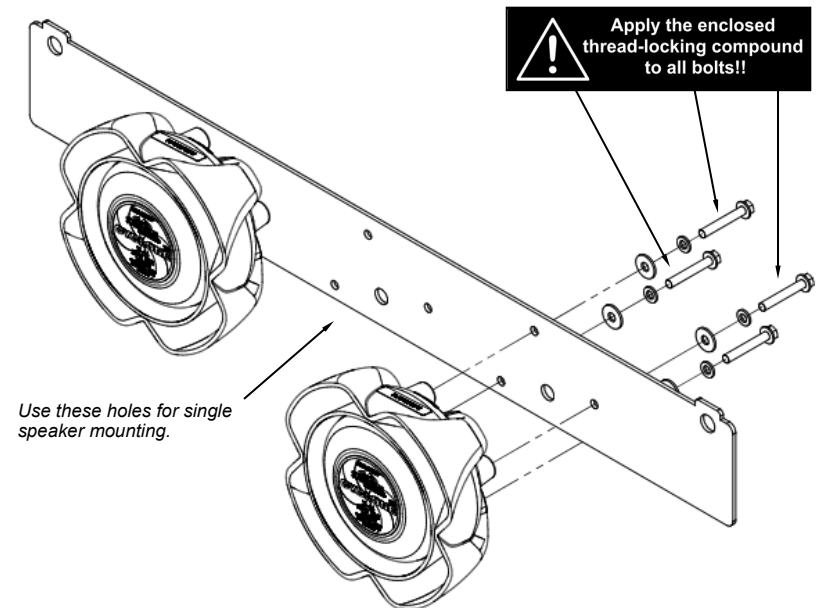

2. Access the front bumper extrusion by removing the front fascia/grill/bumper cover assembly per manufacturer instructions.

3. Remove the box-shaped speaker shroud from the vehicle.

4. Install speaker and bracket assembly to bumper system over the existing mounting bolts as pictured to the right (speakers removed for clarity).

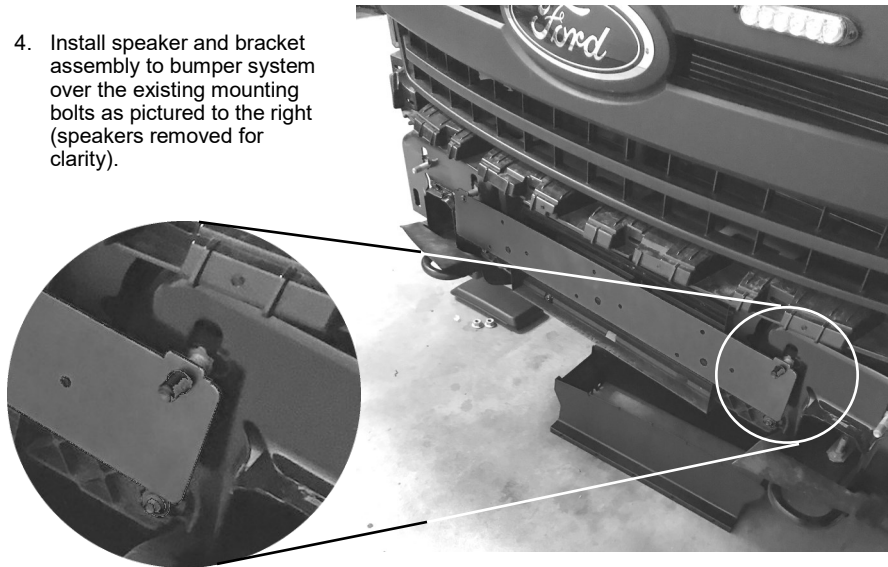

5. Route your wires and make the necessary electrical connections.



6. Replace the speaker shroud.

7. Re-install the front fascia/grill/bumper cover assembly.



WARNING: ALWAYS WEAR HEARING PROTECTION PER OSHA 1910.95

!!! WARNING !!!

Devices should be mounted only in locations listed in SAE standard J1849. Assure clearances before drilling in vehicle. Sound levels produced by speakers can cause permanent hearing loss. Never operate this unit without adequate hearing protection for you and others in the area. (OSHA 1910.95)

ONE YEAR LIMITED WARRANTY

Star Safety Technologies warrants this product against factory defects in material and workmanship for one year after the date of manufacture. The owner will be responsible for returning to the Service Center any defective item(s) with the transportation costs prepaid. The manufacturer will, without charge, repair or replace *at its option*, products, or part(s), which its inspection determines to be defective. Repaired or replacement item(s) will be returned to the purchaser with transportation costs prepaid from the service point. A copy of the purchaser's receipt must be returned with the defective item(s) in order to qualify for the warranty coverage. Exclusions from this warranty include, but are not limited to the finish. This warranty shall not apply to any product, which has been altered, such that in the manufacturer's judgment, the performance or reliability has been affected, or if any damage has resulted from abnormal use or service.

There are no warranties expressed or implied (including any warranty of merchantability or fitness), which extend this warranty period. **The loss of use of the product, loss of time, inconvenience, commercial loss or consequential damages, including costs of any labor, are not covered.** Star reserves the right to change the design of the product without assuming any obligation to modify any product previously manufactured.

This warranty gives you specific legal rights. You might also have additional rights that may vary from state to state. Some states do not allow limitations on how long an implied warranty lasts. Some states do not allow the exclusion or limitation of incidental or consequential damages. Therefore, the above limitation(s) or exclusion(s) may not apply to you.

If you have any questions concerning this or any other product, please contact our **Customer Service Department** at (585) 226-9500.



PROUDLY MADE IN THE USA
An ISO 9001:2015 Certified Company

If you have any questions concerning this or any other product, please contact our **Customer Service Department** at (585) 226-9787.

If a product must be returned for any reason, please contact our Customer Service Department to obtain a Returned Materials Authorization number (RMA #) before you ship the product back. Please write the RMA # clearly on the package near the mailing label.

STAR

Safety Technologies by *Cpota*

455 Rochester Street Avon, NY 14414
585-226-9500 (F) 888-478-2797
www.StarSafetyTechnologies.com